

$\phi M12 p0.8$
 $\phi 12 \begin{smallmatrix} 0 \\ -0.02 \end{smallmatrix}$
 $\phi 12 \begin{smallmatrix} 0 \\ -0.02 \end{smallmatrix}$
 $\phi M12 p0.8$

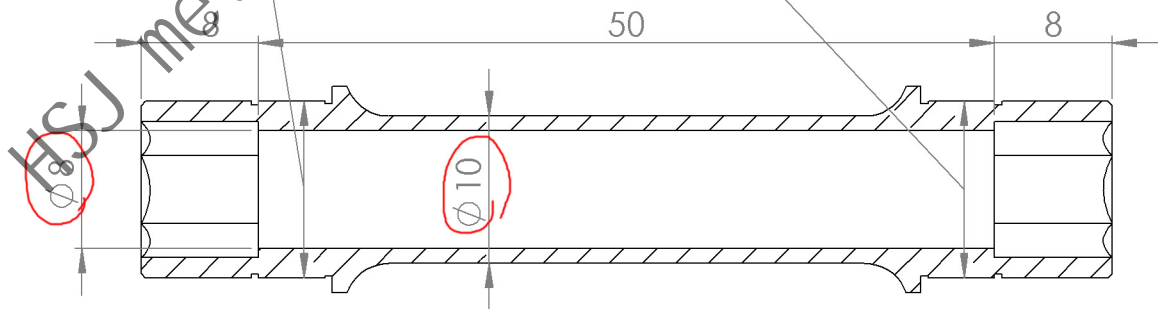

단면 A-A
 축척 2:1

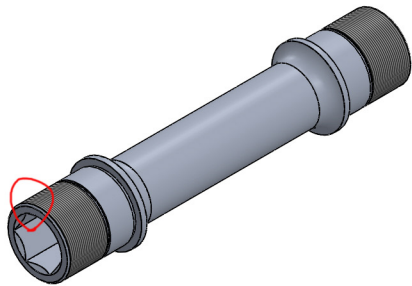

昊盛嘉

HSJ metal fabrication

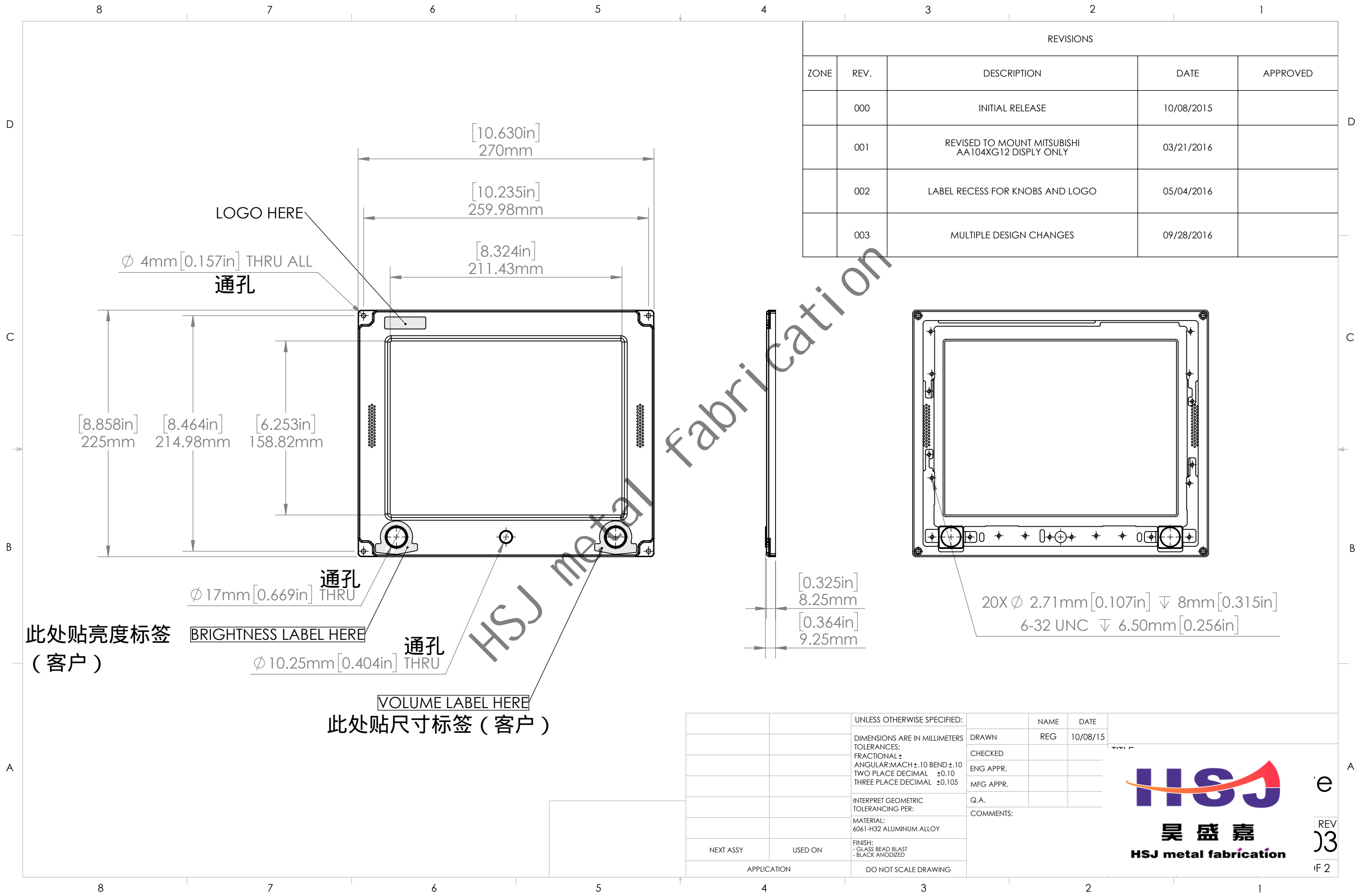

REVISIONS				
ZONE	REV.	DESCRIPTION	DATE	APPROVED
	000	INITIAL RELEASE	10/08/2015	
	001	REVISED TO MOUNT MITSUBISHI AA104XG12 DISPLY ONLY	03/21/2016	
	002	LABEL RECESS FOR KNOBS AND LOGO	05/04/2016	
	003	MULTIPLE DESIGN CHANGES	09/28/2016	

此处贴亮度标签
(客户)

BRIGHTNESS LABEL HERE

VOLUME LABEL HERE
此处贴尺寸标签 (客户)

		UNLESS OTHERWISE SPECIFIED:		NAME	DATE
		DIMENSIONS ARE IN MILLIMETERS	DRAWN	REG	10/08/15
		TOLERANCES:	CHECKED		
		FRACTIONAL ±	ENG APPR.		
		ANGULAR: MACH ± .10 BEND ± .10	MFG APPR.		
		TWO PLACE DECIMAL ± 0.10	Q.A.		
		THREE PLACE DECIMAL ± 0.105	COMMENTS:		
		INTERPRET GEOMETRIC TOLERANCING PER:			
		MATERIAL:			
		6061-H32 ALUMINUM ALLOY			
NEXT ASSY	USED ON	FINISH:			
		- GLASS BEAD BLAST			
		- BLACK ANODIZED			
APPLICATION		DO NOT SCALE DRAWING			

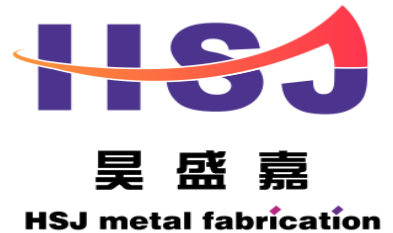

REV 03
OF 2

4

3

2

1

TAG	X LOC	Y LOC	SIZE
A1	14.96	93.20	ϕ 2.71 ∇ 7 6-32 UNC ∇ 5.97
A2	14.96	151.05	ϕ 2.71 ∇ 7 6-32 UNC ∇ 5.97
A3	16.50	205.50	ϕ 2.71 ∇ 7 6-32 UNC ∇ 5.97
A4	17.50	72	ϕ 2.71 ∇ 7 6-32 UNC ∇ 5.97
A5	17.50	166.90	ϕ 2.71 ∇ 7 6-32 UNC ∇ 5.97
A6	17.74	18	ϕ 2.71 ∇ 7 6-32 UNC ∇ 5.97
A7	52.27	18	ϕ 2.71 ∇ 7 6-32 UNC ∇ 5.97
A8	78.63	19.20	ϕ 2.71 ∇ 7 6-32 UNC ∇ 5.97
A9	102.63	19.20	ϕ 2.71 ∇ 7 6-32 UNC ∇ 5.97
A10	125	18	ϕ 2.71 ∇ 7 6-32 UNC ∇ 5.97
A11	145	18	ϕ 2.71 ∇ 7 6-32 UNC ∇ 5.97
A12	167.37	19.20	ϕ 2.71 ∇ 7 6-32 UNC ∇ 5.97
A13	191.37	19.20	ϕ 2.71 ∇ 7 6-32 UNC ∇ 5.97
A14	217.74	18	ϕ 2.71 ∇ 7 6-32 UNC ∇ 5.97
A15	252.27	18	ϕ 2.71 ∇ 7 6-32 UNC ∇ 5.97
A16	252.50	67	ϕ 2.71 ∇ 7 6-32 UNC ∇ 5.97
A17	252.50	166.90	ϕ 2.71 ∇ 7 6-32 UNC ∇ 5.97
A18	253.50	205.50	ϕ 2.71 ∇ 7 6-32 UNC ∇ 5.97
A19	255.04	83.95	ϕ 2.71 ∇ 7 6-32 UNC ∇ 5.97
A20	255.04	141.80	ϕ 2.71 ∇ 7 6-32 UNC ∇ 5.97

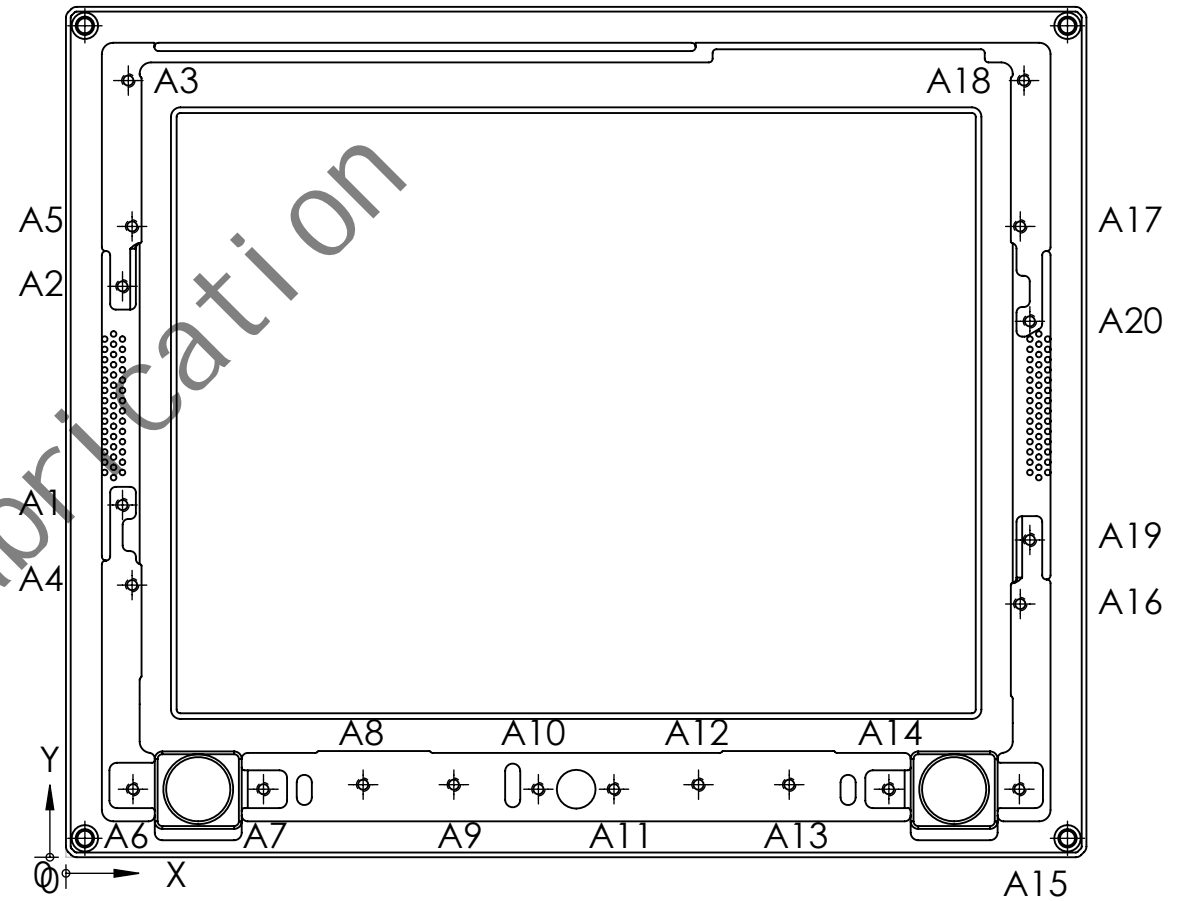

昊盛嘉

HSJ metal fabrication

UNLESS OTHERWISE SPECIFIED:		NAME	DATE
DIMENSIONS ARE IN MILLIMETERS		DRAWN	REG 10/08/16
TOLERANCES:		CHECKED	
FRACTIONAL \pm		ENG APPR.	
ANGULAR: MACH \pm BEND \pm		MFG APPR.	
TWO PLACE DECIMAL \pm		Q.A.	
THREE PLACE DECIMAL \pm		COMMENTS:	
INTERPRET GEOMETRIC TOLERANCING PER:			
MATERIAL			
NEXT ASSY	USED ON		
APPLICATION			
DO NOT SCALE DRAWING			

TITLE
Faceplate noise
Callouts

SIZE DWG. NO. REV
B OM4-P02-R3 000

SCALE: 1:2 WEIGHT: SHEET 2 OF 2

4

3

2

1



昊盛嘉

HSJ metal fabrication

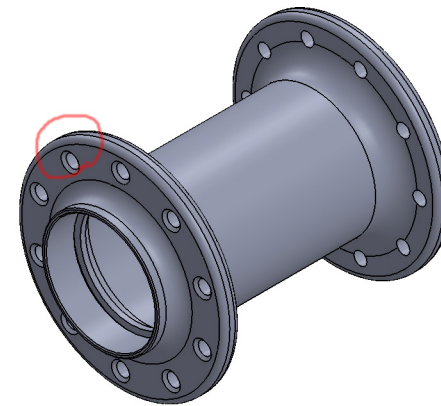
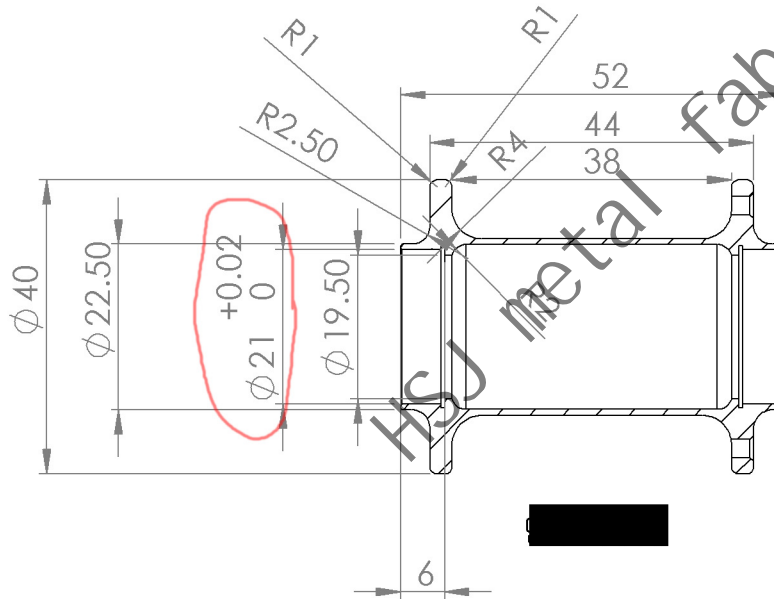
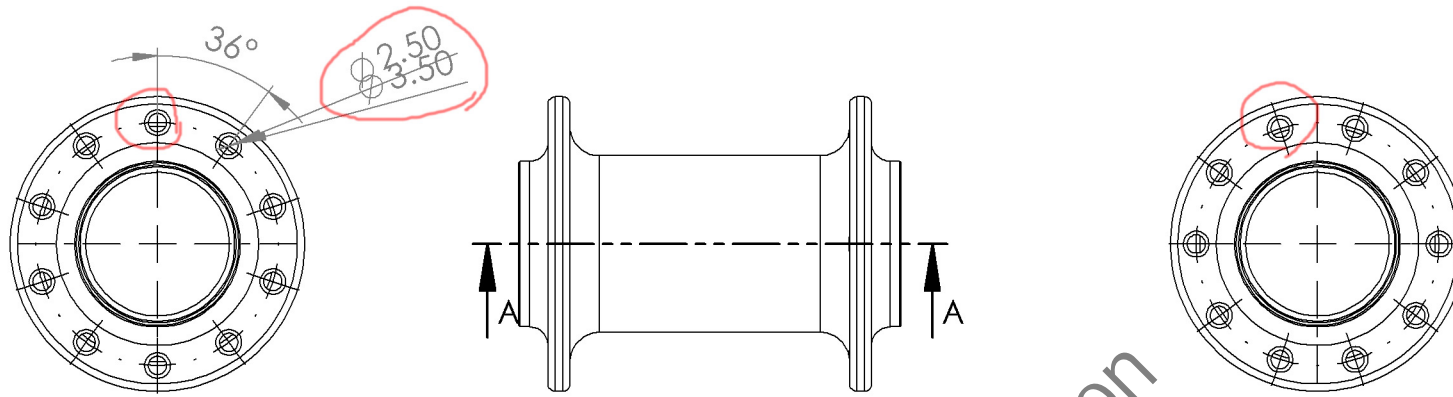



昊盛嘉

HSJ metal fabrication

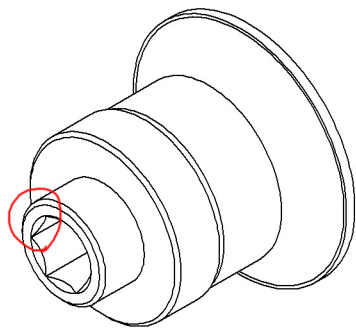
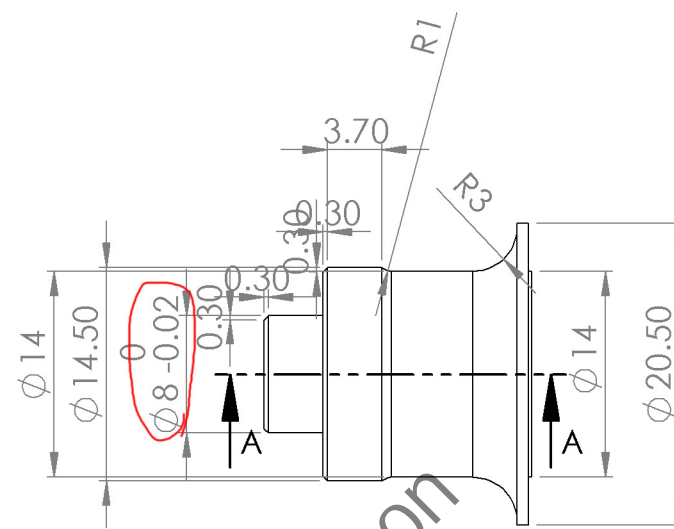
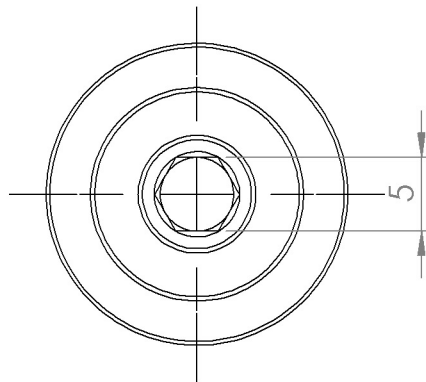

YXPO160436(jack)6#
材料：铝7075

表处：银色喷砂氧化

HSJ metal fabrication

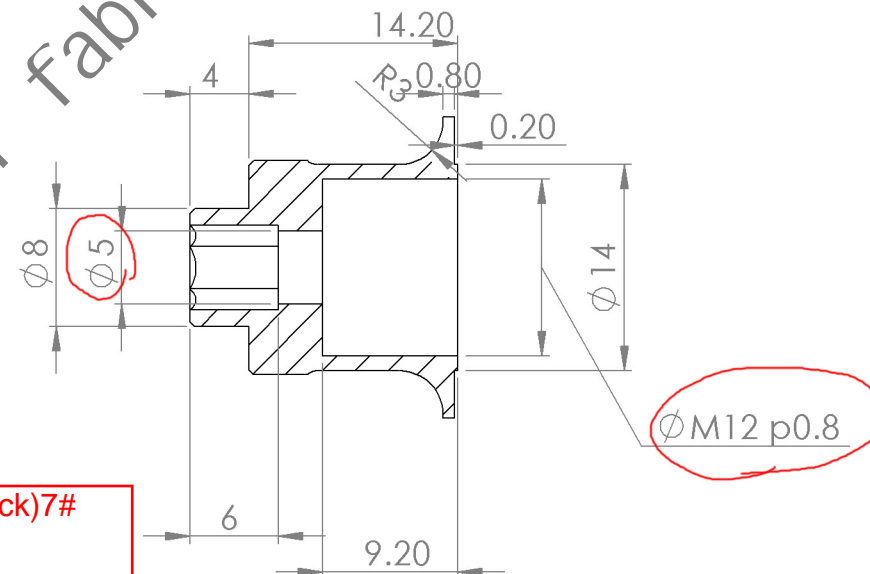

YXPO160436(jack)7#
材料：铝7075

表处：黑色喷砂氧化